

# Health Monitoring and Breathing Support System

Muhammad Awais<sup>1</sup>, Muhammad Nasir Khan<sup>1</sup>, Muhammad Hassan Khan<sup>2</sup>, and Sadaat Abbas<sup>1</sup>

<sup>1</sup>Department of Electrical Engineering, The University of Lahore, Pakistan

<sup>2</sup>School of Computing and Mathematics, Charles Sturt University Sydney, Australia

Corresponding author: Muhammad Awais (e-mail: bsee00178123@gmail.com).

Received: 10-02-2022, Revised: 20-04-2022, Accepted: 12-06-2022

**Abstract**— The objective of this project is design and implementation of a health monitoring system using pulse oximeter which measures pulse rate and oxygen level. Before and especially during Covid-19 pandemic pulse oximeter is most necessary in intensive care units (ICU) and in operation rooms but there is a general shortage of such equipment and the one that is available is very expensive. In this project we aim to create an affordable device that allows a person to measure their physiological parameters and provide breathing support so that it may be used in homes and in medical facilities. This device is controlled by programmable microcontroller with some peripherals and sensor. First, the device was built in breadboard afterward it was built on vero board. This device is based on the variation of photon. This device measures pulse rate, body temperature and oxygen level with oxygen saturation of hemoglobin in blood. This device allows a patient to monitor their health at home which is especially useful for Covid patients observing self-isolation and it can be easily set up in remote areas and can be operated on battery. It is an affordable method of allowing people to monitor their health and avoid frequent visits to hospitals and clinics. The device contains a bag valve mask (BVM) that is compressed using a motor to allow for breathing supports for patients in critical condition.

**Index Terms**— Pulse oximeter, oxygen saturation, microcontroller, signal processing.

## I. INTRODUCTION

THE history of oximetry can be traced all the way back to 1760, Dr Earl Wood first presented oximeter in a medical environment when he attached a cuff with it which allowed for a bloodless zero reference[1]. Later many upgrades were made to it such as an ear oximeter with eight wavelengths. But modern version of oximeter started showing up around 1972 in Japan by Engr Takuo Aoyagi who implemented an oximeter which could utilize light at two wavelengths one of them were red and other is Infrared (IR) [2][3]. It could measure saturation of oxygen (SaO<sub>2</sub>) in blood by only measuring the pulsatile component of blood [11].

Pulse Oximeter is able to measure the SaO<sub>2</sub> which is oxygen saturation in arterial blood. Oxygen saturation can be defined as total number of hemoglobin found in oxidized blood, for a

normal healthy person it is around 98%. Pulse oximeter is able to measure SaO<sub>2</sub> in blood continuously and it is able to do so in a safe way. It measures at capillary level so Oximeter actually measures SpO<sub>2</sub> which is oxygen saturation in peripheral blood.

The basic working of Pulse Oximeter is based on spectrophotometry which is a method based on the measurement of total amount of light that is absorbed by a body as rays of light are passing through it. Any substance will absorb or transmit light over a certain range of wavelength. To measure intensity of light a photodetector is used. In oximeter spectrophotometry is performed on hemoglobin present in blood. Hemoglobin has different colors based on if it is oxygenated or deoxygenated. OxyHemoglobin (HbO<sub>2</sub>) is brighter shade of red and Hemoglobin (Hb) (deoxygenated) is dark red, so it can absorb several wavelengths. Hemoglobin absorbs much more light than OxyHemoglobin. We can calculate the oxygen saturation at two different wavelengths of light in one place by measuring the total amount absorbed by blood.

Pulse oximeter also has some limitations when applied practically as is the case for every sensor, this project uses MAX30100 pulse oximeter module shown in figure 1.2. A few of these limitations that were found during initial testing are mentioned here. Scattering effect is not considered which will happen at instances where the radiation is being crossed. Any ambient light may alter results if the sensor is not properly enclosed. Inappropriate placement of sensor. Nail polish can be reflexive. Moving the finger will shift the sensor causing change in optical path.

Thermistor is simply just a resistor whose resistance depends upon change in temperature. The word thermistor is a combination of thermal and resistor. Thermistor can be of two types which are Negative temperature co-efficient (NTC) and Positive temperature co-efficient (PTC). In this paper, we are using NTC thermistor. NTC is a resistor whose resistance decrease as increase in temperature. The range of this thermistor is between -100C to 300C [6]. To calculate the temperature of thermistor we need to know the thermistor resistance and some constants, thermistor resistance is calculated by finding output voltage across the thermistor using a voltage divider circuit. If the input voltage  $V_{in}$  is 5 volts and the thermistor resistance is maximum at 10k then voltage across

thermistor volt will be 2.5 volts. When temperature increases the resistance across thermistor will decrease which will increase the output voltage. Thermistor resistance and temperature is calculated using equations below [5].

$$V_{out} = \left( \frac{V_{in} \times R_t}{R + R_t} \right) \quad (1)$$

It can find the value of resistance of thermistor  $R_t$  using voltage divider.

$$R_t = R \left( \frac{V_{in}}{V_{out}} \right) - 1 \quad (2)$$

## II. MICROCONTROLLER WORKING

In 1969 the first Microprocessor and Microcontroller were introduced. After microcontrollers were introduced they evolved at a very rapid pace, these days we can see microcontroller in each things from smoke detector to most complex aircrafts [7]. In embedded system a microcontroller play an important role because of its unique characteristics, small size, low cost, integrated solutions and efficient. It has all the necessary component like Random Access Memory (RAM), Read Only Memory (ROM) and peripherals. It is a low-cost small device with low consumption and less connections. A microcontroller can perform many tasks that collectively allow it to control various electrical systems [8-12]. As compared to microprocessor, the microcontroller has issues such as lower speed and performance. as shown in Fig. 1.

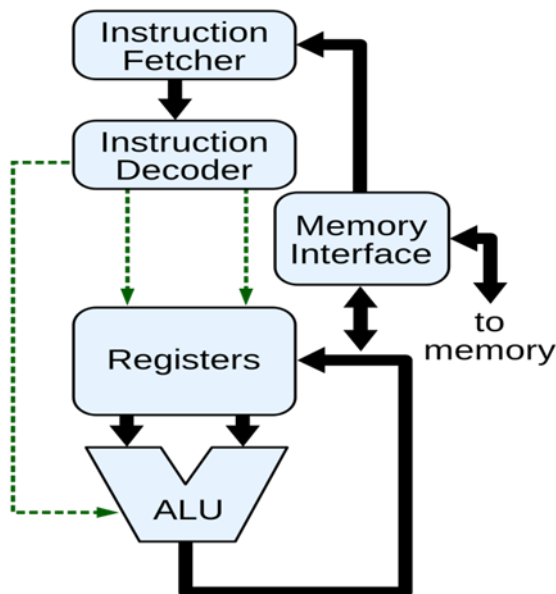

Fig. 1. Block diagram of CPU [8].

The hardware which stores the data is called memory. The architecture of microcontroller is called Harvard, in this type of architecture address and data bus are separated from each other. Memory used for programming is also called ROM. This memory stores data even when power off. It is also known as electrically erasable programmable read only memory (EEPROM). The

other memory is RAM. This memory lost all data when power off [13, 14].

Arduino atmega is a widely used microcontroller. It has 1 EEPROM, 2 kb RAM, 23 pins used for General Purpose Input and Output (GPIO), 32 registers used for General Purpose (GP), 3 timers for internal and external interrupts, universal synchronous asynchronous receiver transmitter (USART) and programmable watchdog timers [14]. This device operate between 1.8 and 5.5 volts. The detail of interfacing max30100 with this controller is explained in next segment. This project uses two arduino atmega328p microcontrollers. One is for sensors and other for controlling the motor using motor driver circuit.

Now we are interfacing Max30100 pulse oximeter module and 10k thermistor with microcontroller. With this module we can measure pulse rate, oxygen level and body temperature of a person. The Max30100 has 4 pins one is serial clock (SCL) and second is serial data (SDA) and two others are power pins. We are using LCD with inter integrated circuit (I2C) module which also has SCL and SDA pins [15-18]. So we have connected the Max30100 and LCD pins. With this Microcontroller we are also measuring body temperature so we have connected the single pin of thermistor to the analog pin of Microcontroller. Figure 2 shows the connection of max30100 oxymeter module and thermistor with microcontroller and display. The Fig. 2 was created using Fritzing software as max30100 does not have libraries in proteus for simulation.

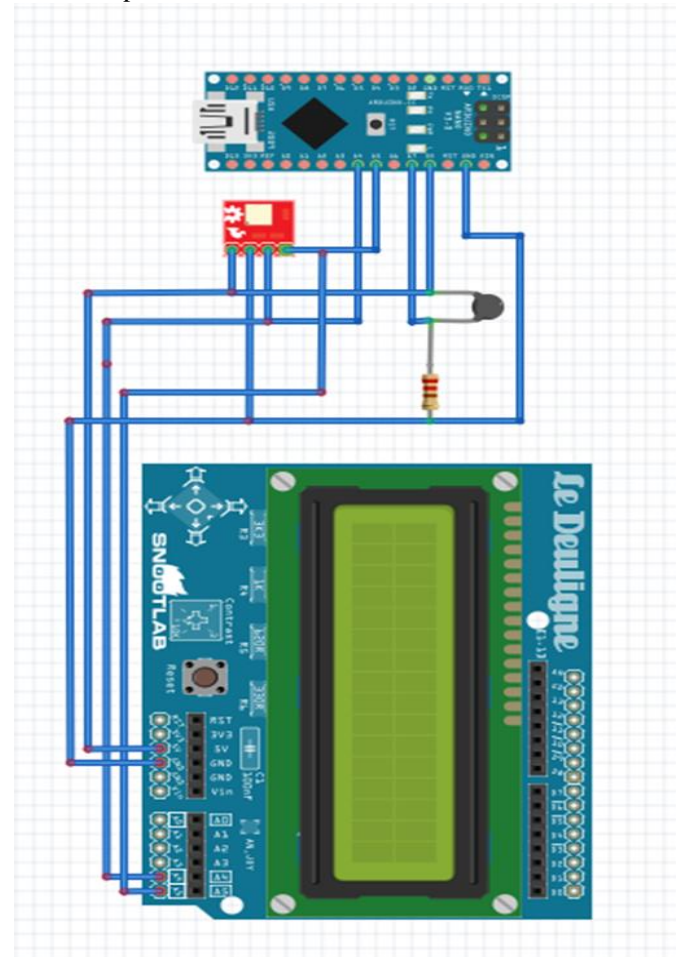

Fig. 2. Connection of max30100 and thermistor with controller.

### III. DC MOTOR AND HARDWARE

The breathing support uses a bag valve mask (BVM) to provide forced breathing to a patient. The BVM is hand operated by highly trained medical staff. This project uses a DC gear motor to compress the BVM bag. Using a motor allows for high degree of control over the compression and decompression in turn providing better control over the air pressure exerted on a patient and breathe per minute rate. This greatly reduces the risks of using BVM which are created due to human error such as high air pressure being exerted on lungs and irregular BPM rate both of which can be dangerous for patient [17]. A DC motor can simply be defined as a device that transforms electrical energy into mechanical energy in form of torque. In Gear motor Gearbox is attached to the head of the motor which reduces the speed while increasing the torque.

This project uses a DC gear motor to compress the BVM bag. The motor has an inductor coil inside it which creates a magnetic field that creates rotating motion as DC voltage is applied to the terminals. Magnets are placed on both sides of the shaft forming north and South Pole which cause both an attractive and repulsive force. A gear assembly is attached to the motor which allows for increase of torque while reducing the speed [16]. It uses a 24V and 13rpm capable of producing 6kg Torque. Speed of motor is being controlled by Pulse Width Modulation (PWM) which is produced by the controller and fed to motor driver module L298n. The controller is coded to operate motor and switch direction of rotation of motor based on limit switch input. It will also show the current duty cycle and breaths per minute on display.

This device uses a 16×2 liquid crystal display (LCD), 1298n motor driver, dc gear motor, limit switches, potentiometer and microcontroller for the breathing support system. Figure 3 shows the simulation of dc motor in Proteus. Limit switches are being used in this project to stop and reverse the direction of motor to allow for decompression of BVM bag. Limits switch is an electromechanical device consisting of an actuator which is linked to an electrical switch when an object hits the actuator it will operate the switch [19]. As the motor starts rotating it will compress the bag. Once the bag is fully compressed, the mechanism triggers a limit switch that reverses the direction of motor. The motor now rotating in opposite direction will allow the bag to decompress once it fully decompresses another limit switch will be triggered causing the direction of rotation to change again compressing the bag. Potentiometer is used to control the voltage provided to the motor to control it's speed through PWM signal. L298n motor driver module is used to operate the motor, it is a dual h bridge motor driver it has six signal wires [20], two of which are for enable that is controlled by PWM for motor speed and other four are for controlling the direction of rotation.

### IV. HARDWARE IMPLEMENTATION

This segment discusses the details of various hardware components of this project, their assembly and their purpose. The components are enclosure, motor, clamp, controller, power supply, motor driver, display, potentiometer, limit switches,

LED, buttons, power sockets.

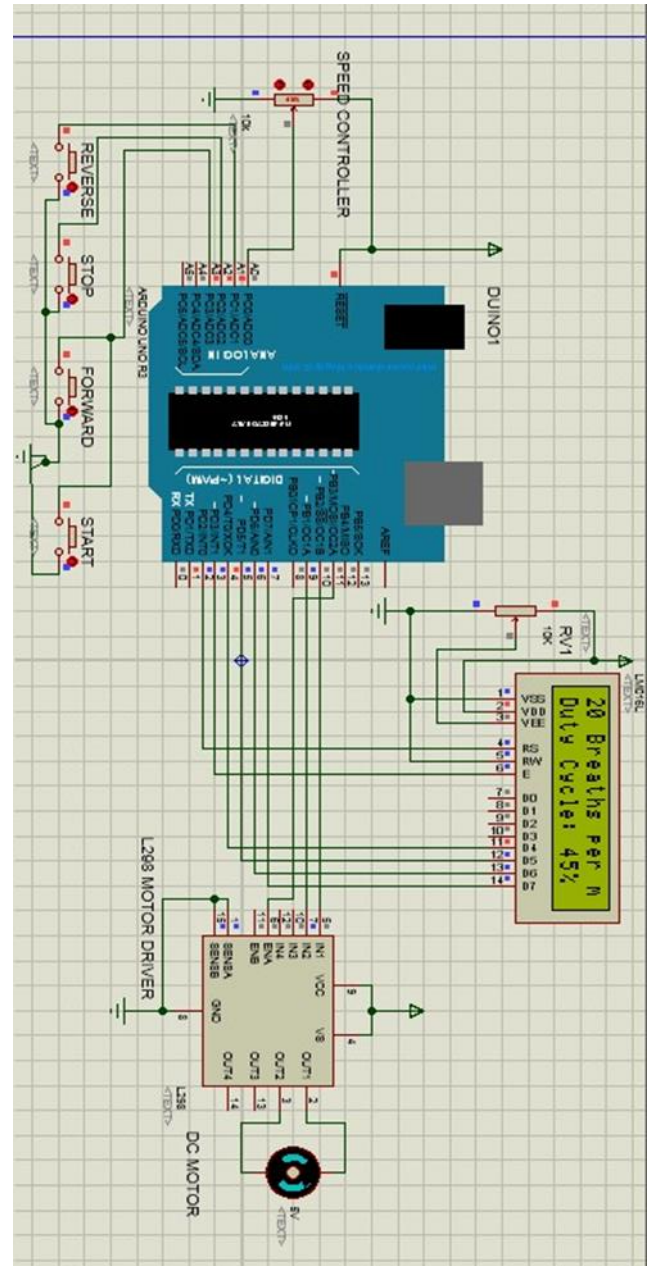

Fig. 3. Simulation of DC motor.

The box is made of clear acrylic sheets as shown in Fig. 4, that have been cut according to custom size to occupy minimum space while easily enclosing the project. Fitted together using screws. The enclosure was designed on coral draw and cut using computer numeric control (CNC) machine, the placement for LCD, buttons, potentiometer and power sockets was decided and cut accordingly. The dimensions for the enclosure are: - length 45cm, width 25cm and height 30cm.

The DC gear motor is connected firmly to the base of the box. Motor has been coupled to a gear using a shaft coupler. We have taken a robotic clamp and modified it according to the project's requirements, the clamp is coupled with the motor using a small gear. A wooden curved arm is attached to the clamp that compresses the bag. As the motor rotates the clamp starts

closing in compressing the bag, when the direction of rotation changes on the motor the clamp starts to open up allowing the bag to decompress. Figure 5 shows coupling of motor with clamp and gear.

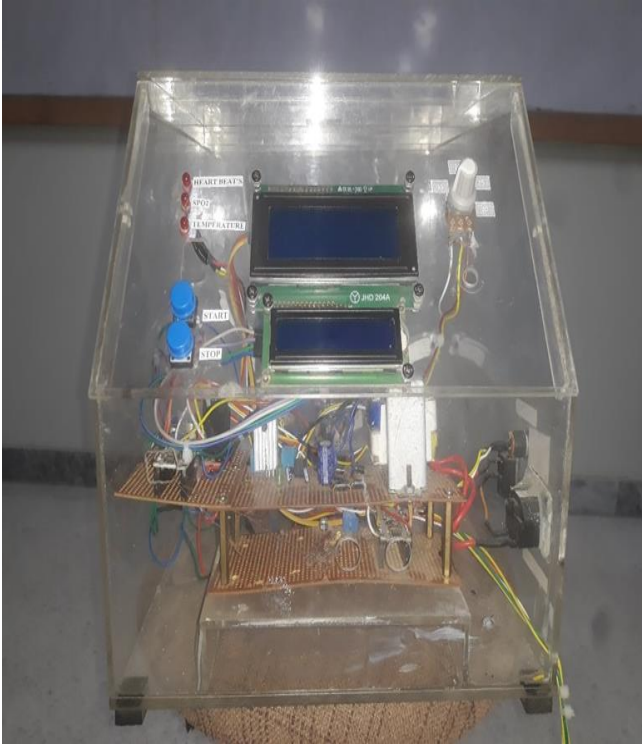

Fig. 4. Acrylic Box.

from 12v to 36v. The two controllers are placed on a separate vero board along with motor driver module.

Figure 6 shows the veroboards of microcontroller and power supply. The project includes input port for AC 220v supply that can be used at homes or at medical facilities easily with an adapter and a port connection for 12-36V DC for a battery that allows it to be used in remote areas or while moving such as in an ambulance shown in Fig. 7.

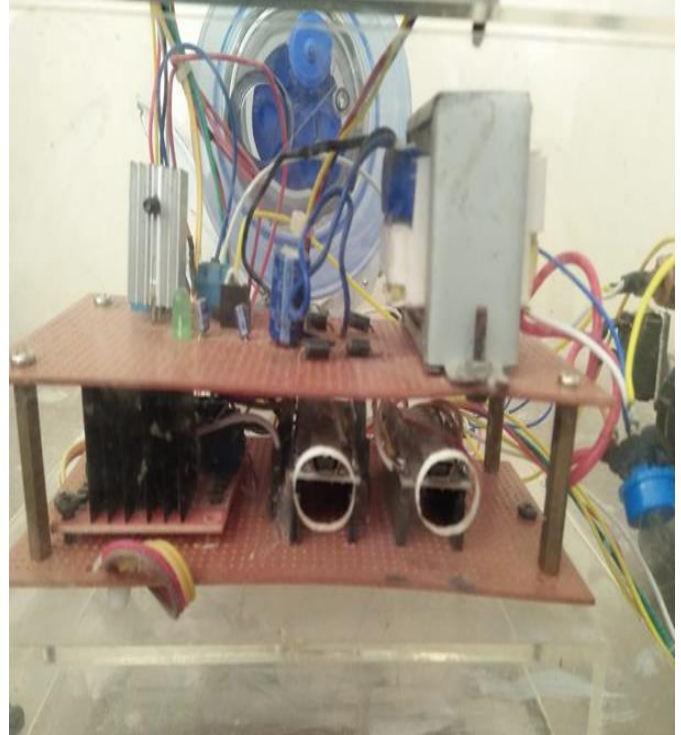

Fig. 6. Power supply and microcontroller.



Fig. 4. Motor and clamps.

This project uses a custom power supply that can take input 220v alternating current (AC), 220v are given to a step down transformer that gives 24v AC, the 24v are converted to DC using a bridge rectifier circuit and a filter. Then a voltage regulator converts 24v DC to linear 5v DC which are used to power the controller. It also allows a battery connection ranging

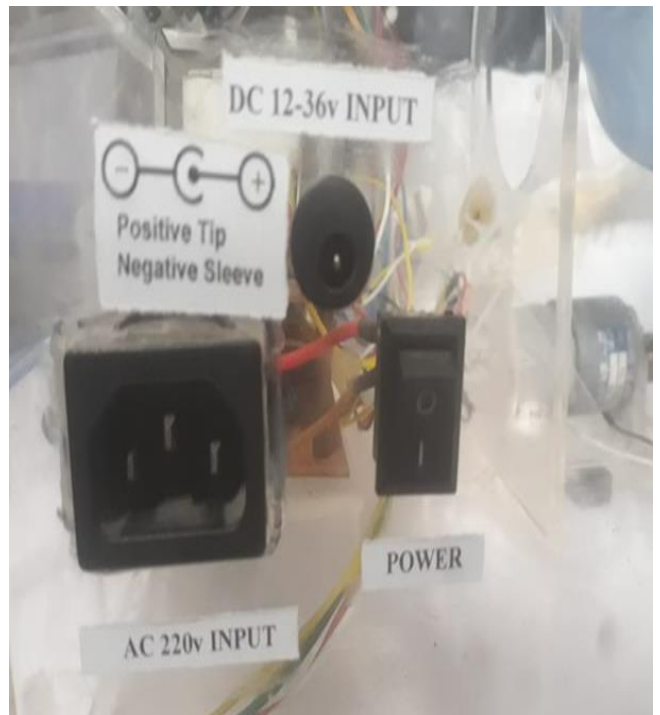

Fig. 7. Input ports of power supply.

Three light emitting diodes (LED) are being used as shown in Fig. 8 for alerting the patient in case of any vital is outside acceptable range. This Led is for alert signal from controller. A buzzer or any such device can also be used in parallel to these led for alerting. First LED turns on when heart beat rate exceeds 100. Second LED turns on when blood oxygen level drops below 95. Third LED turns on if temperature exceed 37.5 degree Celsius.

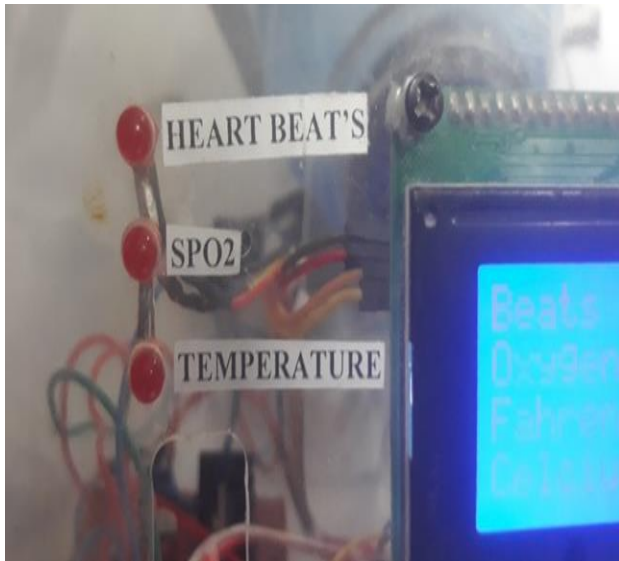

Fig. 8: LED for alerting

This project uses potentiometer also known as variable resistance to control the motor's rotational speed by reducing the voltage. Using this voltage control method for controlling the speed we can control the breath per minute rate. Breaths per minute rate is the number of times the BVM bag is being compressed in one minute which is equal to the number of compression and decompression performed by rotation of motor. Figure 9 shows potentiometers placed in front of the box enclosure for controlling breaths per minute (BPM) ranging from 15BPM to 30BPM.

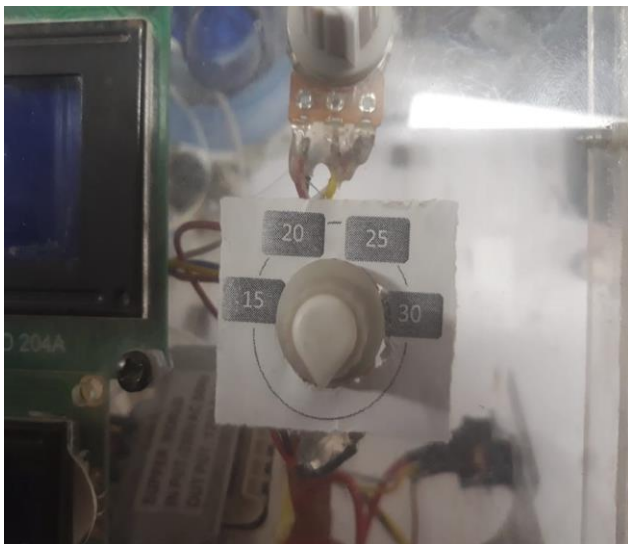

Fig. 9: Potentiometer

To change the direction of rotation for DC gear motor we are using limit switches as explained in segment 4.2. This project uses limit switches for reverse and forward direction. These limit switches are connected with analog pin of microcontroller. It has three pins, one is common, and other two are normally close and normally open. We are using common and normally open. When the wooden arm touches the limit switch it sends an analog signal to the controller, the controller then changes the direction of rotation.



Fig. 10: Limit switch.

We are using two push buttons in this project for stopping starting the breathing support system. These buttons start/stop the compression of the BVM bag. Start button is connected in parallel to limit switch as limit switches are what actually stop or start the process of compression but they cannot be manually turned off as they are placed inside the enclosure, these buttons are then used to disable or enable the limit switches allowing the user to simply turn on or turn off the motor with a push of a button. Figure 11 shows the start/stop buttons.

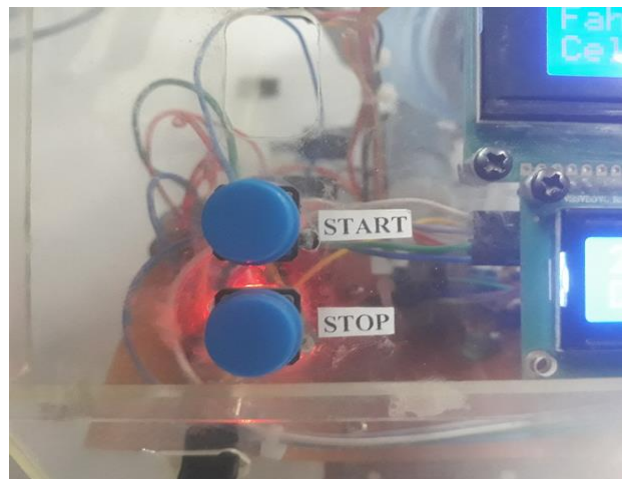

Fig. 11: Start and stop button.

This project uses two LCD displays. Top LCD is 20×4, 20 columns and 4 rows, it is used to show the sensor readings as health parameters such as beats per minute, oxygen level and temperature in Fahrenheit and Celsius all of which are displayed in their own respective columns. Bottom LCD is 16×2, 16 columns and 2 rows, it is used to display the breaths per minute (BPM) rate and duty cycle. Figure 12 shows the two displays and their readings.

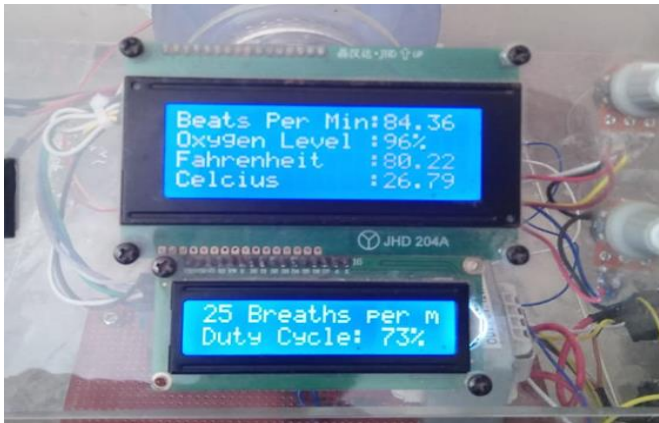

Fig. 12: LCD display.

#### V. APPLICATION ON SOCIETY

Since the outbreak of COVID-19 the world has entered a health crisis. Thousands of people die every day due to Covid and many other diseases. Hospitals have to deal with more patients daily than the capacity for which they are equipped. For most people it has become very difficult to schedule for regular health checkups, this is true specially for old people, many people avoid getting regular health checkups after the start of this pandemic this may be due to increase in patients being hospitalized, long queues for checkup and consultation with doctors requiring more time, the rapid increase in healthcare cost and there is a general fear or paranoia of hospitals among people due to doctors being exposed to COVID patients daily.

COVID patients can exhibit many symptoms which can be any combination of following: high fever, dyspnea which is short breaths, reduced SpO2 level, dry cough and migraines, loss in senses of smell/taste and abnormal pulse rate [10]. Patients can show any of these symptoms among which high fever, reduced SpO2 level, and abnormal pulse rate are the ones which are treated more seriously [15]. For this reason we want to develop an affordable and portable device so that it can be used in hospitals, clinics and at homes. This project aims to create a device to support a patient in a critical situation. It senses and develops a prolong backup to the patient in stabilizing the heart and breathing. The device will monitor and display features such as heart beat rate, blood oxygen level and body temperature, it will alert the patient in case any of the vitals are out of their normal range. It includes a breathing support system that will provide patient with emergency breathing support with controllable Breaths per minute (BPM). The device can be used at hospitals and clinics as well as at homes allowing people observing self-isolation to monitor their health.

#### VI. CONCLUSION

After facing some problems we have been able to make a device that is capable of measuring a person's blood oxygen level SpO2, body temperature and heart beat rate and also provide breathing support for a patient in need. The project is easy to set up as it only requires a 220v standard AC input or it can be used with a battery allowing it to be set up in remote areas with limited electrical power. It is simple to operate as most functions are coded in the controller. The breath per minute rate can be controlled by simply changing the variable resistance. The finished project is cheap enough to meet our desired cost parameter.

#### REFERENCES

- [1] Pole, Yash. "Evolution of the pulse oximeter," International Congress Series, vol. 1242. pp. 137-144. Elsevier, 2002.
- [2] Kastle, S Noller, S Falk, Mayer E and Miller D. "A New Family of Sensors for Pulse Oximetry," Hewlett Packard Journal 48, pp. 39-47, 1997.
- [3] J.W. Severinghaus and P. and Honda Y, "History of blood gas analysis. VII. Pulse Oximetry." Journal of clinical monitoring 3, no. 2, pp. 135-138, 1987.
- [4] Webster, John G, "Design of Pulse Oximeters," CRC Press, 1997.
- [5] Muhammad Nasir Khan, Syed K. Hasnain, Mohsin Jamil, Sameeh Ullah, "Electronic Signals and Systems Analysis, Design and Applications International Edition," in Electronic Signals and Systems Analysis, Design and Applications: International Edition, River Publishers, 2020
- [6] Khan, Muhammad Nasir, Hasnain Kashif, and Abdul Rafay. "Performance and optimization of hybrid FSO/RF communication system in varying weather." Photonic Network Communications vol. 41, no. 1, pp. 47- 56, 2021.
- [7] Jamil, Mohsin, Muhammad Nasir Khan, Saqib Jamshed Rind, Qasim Awais, and Muhammad Uzair. "Neural network predictive control of vibrations in tall structure: An experimental controlled vision." Computers & Electrical Engineering, vol. 89, pp. 106940, 2021.
- [8] Khan, Muhammad Nasir, Mohsin Jamil, Syed Omer Gilani, Ishtiaq Ahmad, Muhammad Uzair, and H. Omer. "Photo detector-based indoor positioning systems variants: A new look." Computers & Electrical Engineering, vol. 83, pp. 106607, 2020.
- [9] Kashif, Hasnain, Muhammad Nasir Khan, and Ali Altalbe. "Hybrid optical-radio transmission system link quality: link budget analysis." IEEE Access, vol. 8, pp. 65983-65992, 2020.
- [10] Khan, Muhammad Nasir, and Fawad Naseer. "IoT based university garbage monitoring system for healthy environment for students." In 2020 IEEE 14th International Conference on Semantic Computing (ICSC), pp. 354-358. IEEE, 2020.
- [11] Carreiras, Joao Manuel Castanho, "A Pulse Oximeter", Technico Lisboa, 2013.
- [12] IDE, Simulator. "MPLAB IDE, Simulator, Editor user's guide." 2000.
- [13] Sedra, A.S, Smith, K.C, Carusone, T.C. and Gaudet, "Microelectronic circuits", Vol. 4 New York: Oxford university press, 2004.
- [14] "Atmega329p", <https://www.microchip.com/en-us/product/ATmega328P>. [online]
- [15] Khan, Mohammad Monirujjaman, Safia Mehnaz, Antu Shaha, Mohammed Nayem, and Sami Bourouis. "IoT-Based Smart Health Monitoring System for COVID-19 Patients." Computational and Mathematical Methods in Medicine, 2021.
- [16] Yao, Chenfeng, and Stanislav S. Voronin, "A Simple Model of Typical Conveyor System with DC Gear Motor", International Conference on Industrial Engineering, Applications and Manufacturing (ICIEAM), pp. 1-5, IEEE, 2018.
- [17] Otten, D., Liao, M.M, Wolken, Douglas, I.S., Mishra, R., Kao, A Barrett, W, Drasler, Byyny, R.L and Haukoos, J.S., "Comparison of bag-valve-mask hand-sealing techniques in a simulated model", Annals of emergency medicine, 63(1), pp. 6-12, 2004.
- [18] Datasheet, <https://datasheets.maximintegrated.com/en/ds/MAX30100.pdf> [online]